

Outdoor Motor Skills-Train-Corner Set - Assembly Instructions

1. Confirm the site is ready before installation, confirm the installation location, measure the size of site and plan the site layout reasonably. Assembly requires impact drill, electric screwdriver and rubber hammer etc.
2. Please do not install the wheels until the foot plate is fixed to the ground with expansion screws.
3. After connecting all the carriages, then fix the foot plate to the ground.
4. The wire ropes connected between the carriages are left to be installed at the end.
5. Only one expansion screw (applicable to concrete floor) or one ground peg (applicable to soft ground or grass ground) is required for each foot plate of each carriage.
6. HW1-S356CK Outdoor Motor Skills-Train-Entrance Carriage- the connection between the foot plates of the 5 entrance steps and the ground:
A, For concrete floor, use expansion screws directly.
B, For soft ground or grass ground, need to dig a hole under the foot plate to make a concrete foundation, then use expansion screws.

Overall assembly sequence:

1. Assemble each carriage (except the wheels)
2. Connect all carriages to each other
3. Connect the wire ropes between each carriage
4. Fix the foot plate to the ground according to the ground type
5. Finally install the train wheels

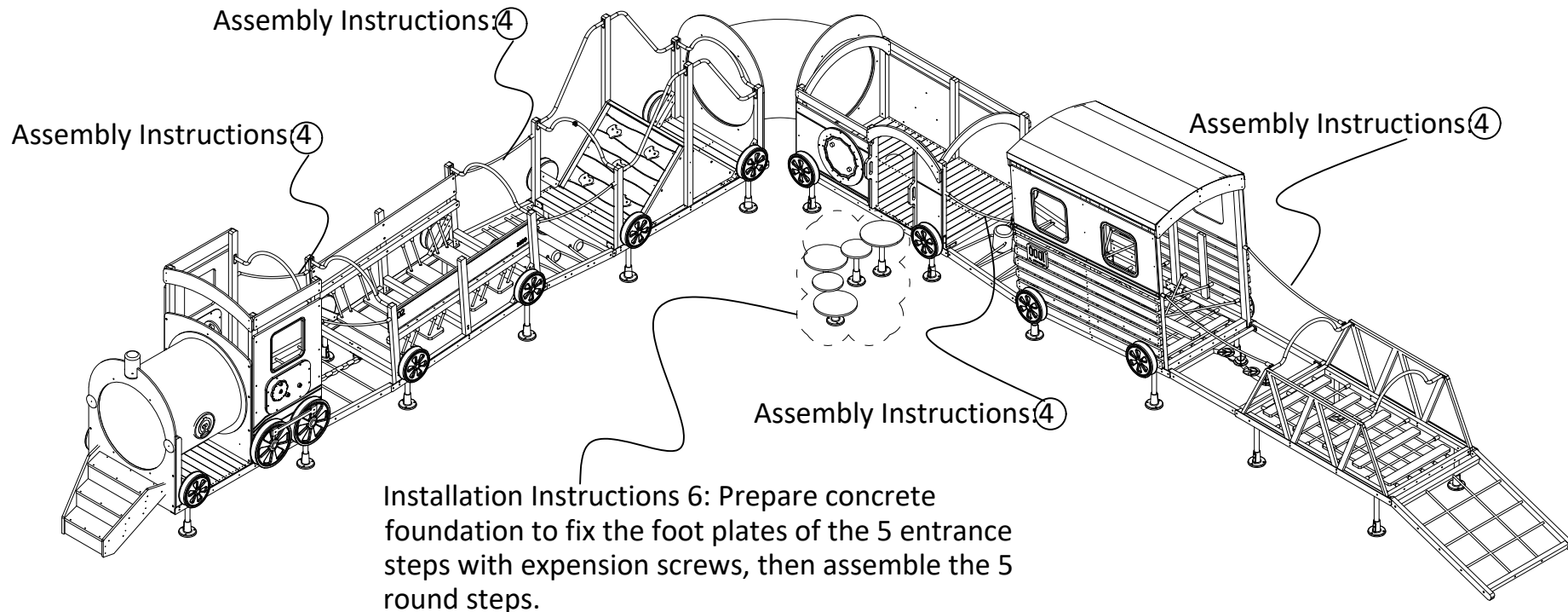

Construction drawings of soft ground or grass ground with concrete foundation

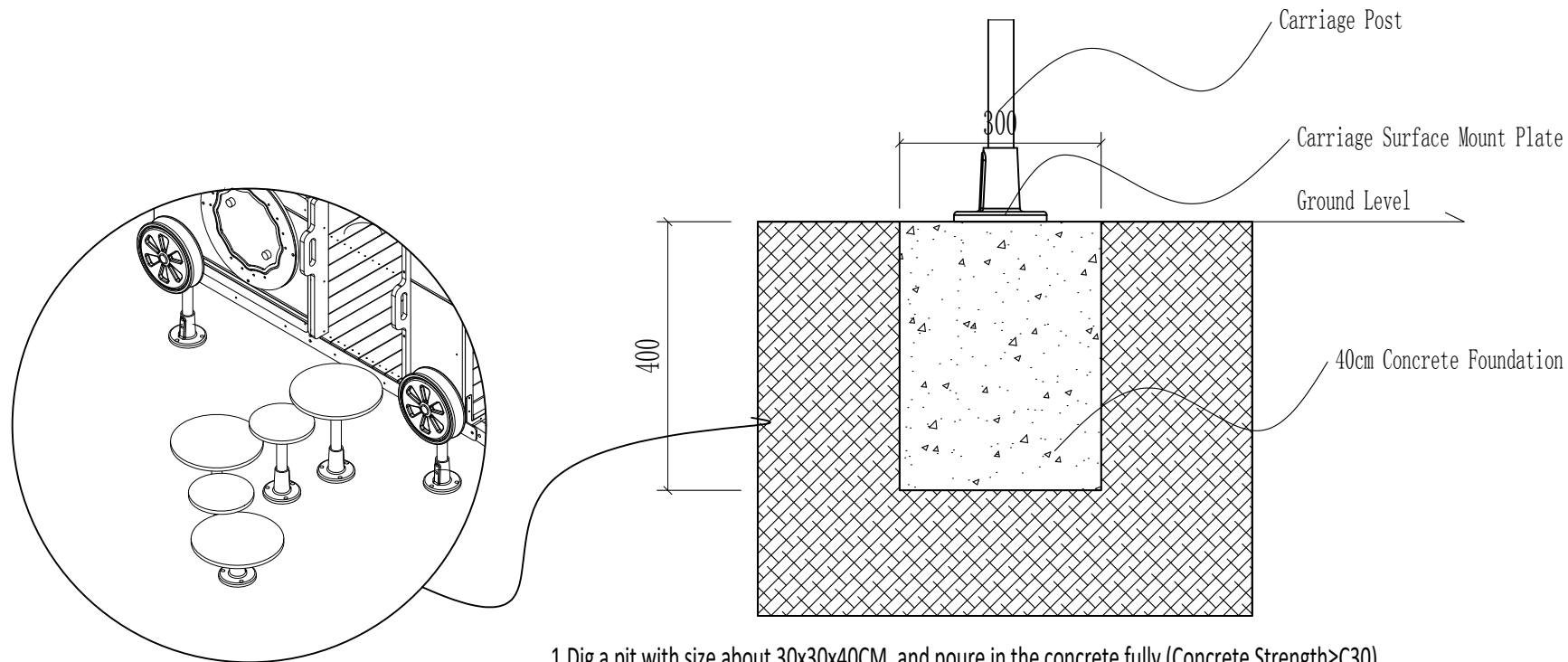

1. Dig a pit with size about 30x30x40CM, and poure in the concrete fully (Concrete Strength \geq C30).
A laser level is required to ensure that the concrete foundations are on the same level.
2. Assemble all the carriages and connect the surface mount plate.

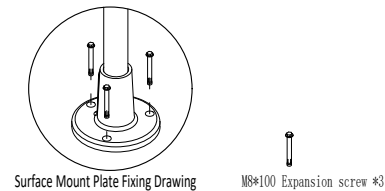
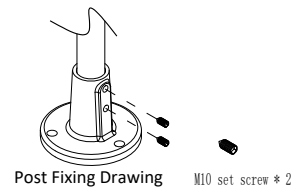

3. After the concrete is completely solidified, put each carriage to the corresponding position, and connect the parts between the carriages in sequence.
4. After completing the above steps, re-calibrate the position, and use percussion drill to drill a M10*120 hole in the foundation through the surface mount plate hole. The drill bit should be required a length of M10*150 or more.
5. Use M8*100 expansion screws to fix the surface mount plate to the foundation.

Concrete Ground

1. Assemble each individual carriage and confirm the position before ground fixing, then connect the parts between the carriages in sequence.

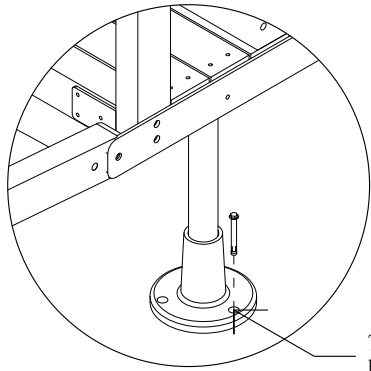

Turn the foot plate to have at least one hole outwards for installation.

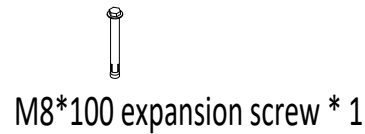

2. Use impact drill to have a M10*120mm hole in the ground through the foot plate hole. The drill bit requires a length of M10*150 or more. Use M8*100 expansion screws to fix the foot plate to the ground.

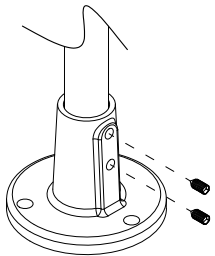

M10 set screw *2

3. Use M10 set screws to connect the foot plate and the foot post.

Soil & Grass Ground

1. Assemble each individual carriage and confirm the position before ground fixing, then connect the parts between the carriages in sequence.

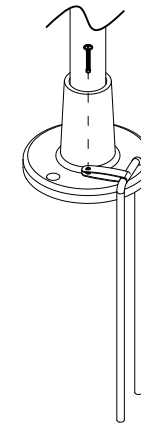

M4*20
X1

Fabric strip*1

(Ground peg)
X1

Turn the foot plate to have at least one hole outwards for installation.

2. Insert ground peg through the foot plate hole and knock it into the ground. Use M4*20 drill-tail screws to connect the fabric strip to the foot plate.

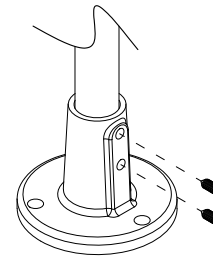

M10 set screw *2

3. Use M10 set screws to connect the foot plate and the foot post.

HW1-S358-A

PART LIST

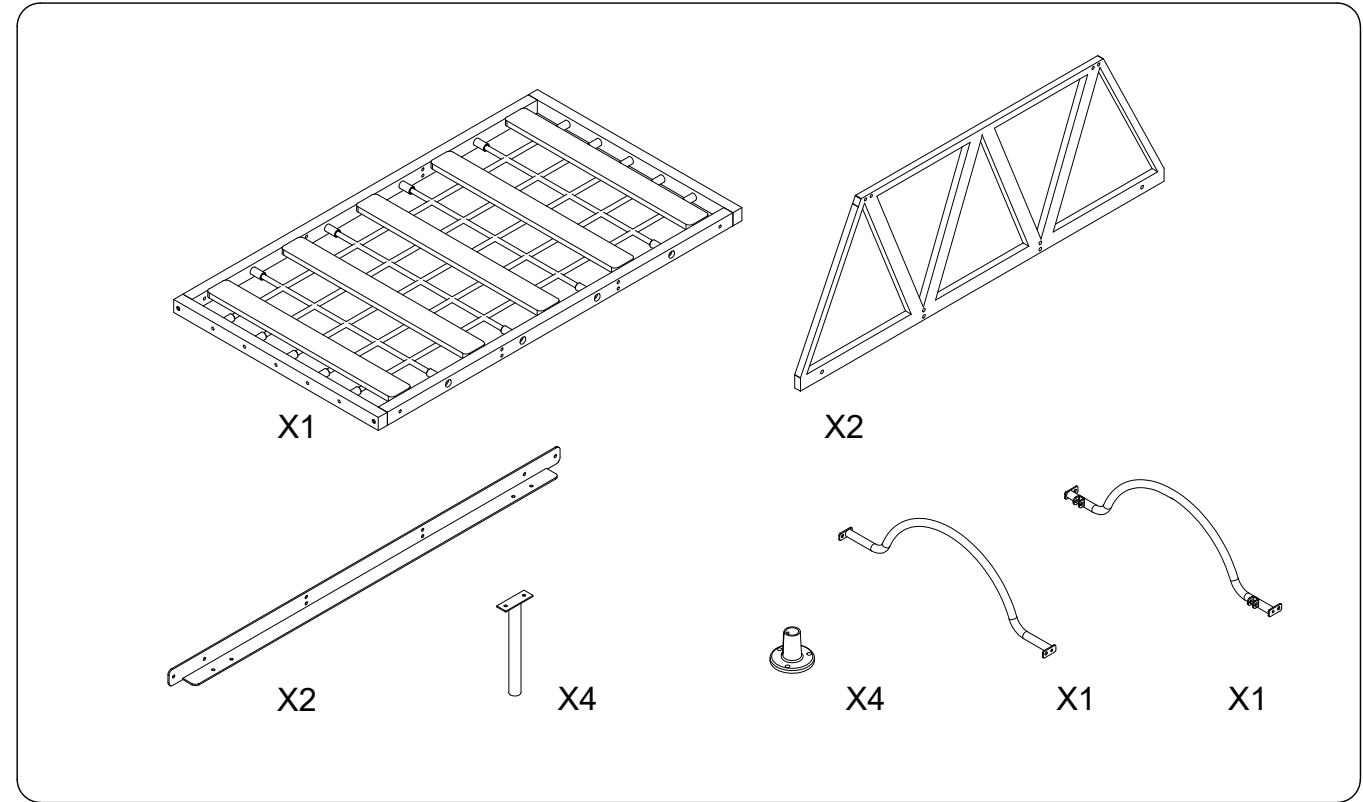
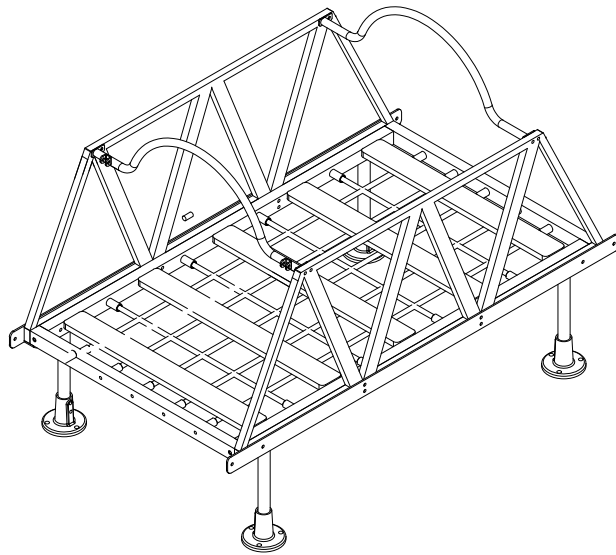

HARDWARE

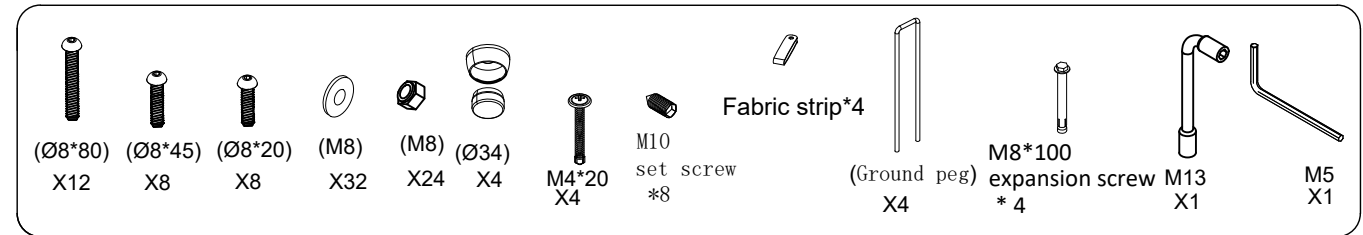

WARNING:

- Contains small parts, sharp points and edges.
- Adult assembly required.
- Two adults recommended.
- Do not stand, sit, kneel, lean or pull on unit for support.
- Never leave children unattended.
- Adult supervision recommended.
- Do not place unit near high heat.

- Enthält im unmontierten Zustand kleine Teile, scharfe Kanten und spitze Ecken.
- Montage durch zwei Erwachsene empfohlen.
- Während der Montage nicht auf den Artikel stellen, sitzen, knien, lehnen o. ä.
- Lassen Sie Ihre Kinder nicht unbeaufsichtigt.
- Benutzung unter Aufsicht Erwachsener.
- Positionieren Sie den Artikel nicht in unmittelbarer Nähe eines offenen Feuers.

TIP!
DO NOT FULLY TIGHTEN SCREWS UNTIL ALL SCREWS HAVE BEEN LOOSELY POSITIONED.

TIP!
ZIEHEN SIE DIE SCHRAUBEN NICHT KOMPLETT AN BEVOR DER ARTIKEL KOMPLETT MONTIERT IST.

BEFORE ASSEMBLING, MAKE SURE THERE ARE NO MISSING PARTS.

BITTE PRÜFEN SIE DEN ARTIKEL UND SEINE BESTANDTEILE VOR MONTAGE AUF SEINE VOLLSTÄNDIGKEIT.



NOTE / HINWEIS:

AN ELECTRIC SCREWDRIVER WILL BE RECOMMENDED FOR ASSEMBLY (NOT INCLUDED)

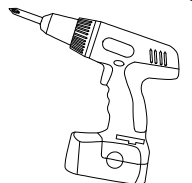

EIN AKKUSCHRAUBER IST FÜR DIE MONTAGE VON VORTEIL (NICHT ENTHALTEN)



1 X2

-  (Ø8*20)
X8
-  (M8)
X8
-  (M8)
X8

2

-  (Ø8*80)
X12
-  (M8)
X12
-  (M8)
X12

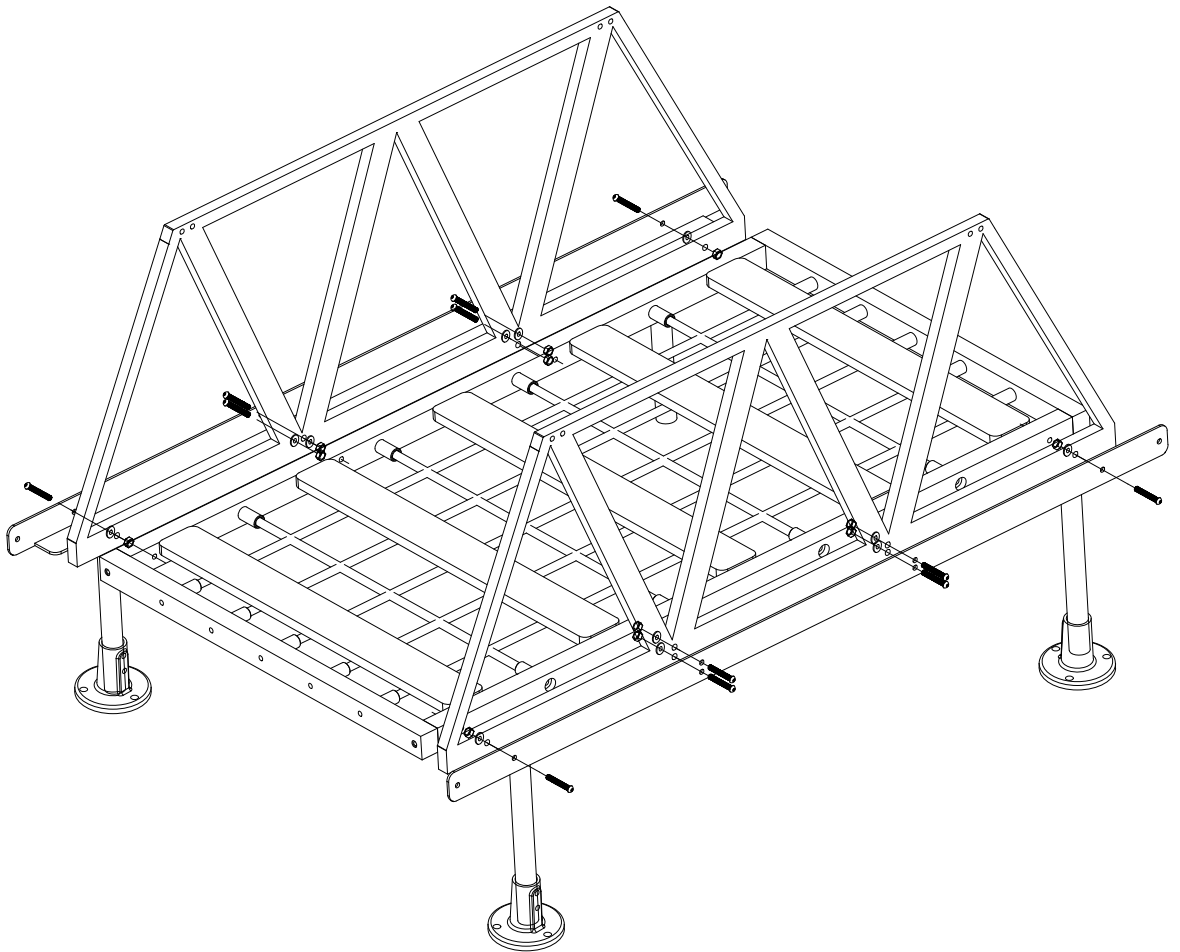
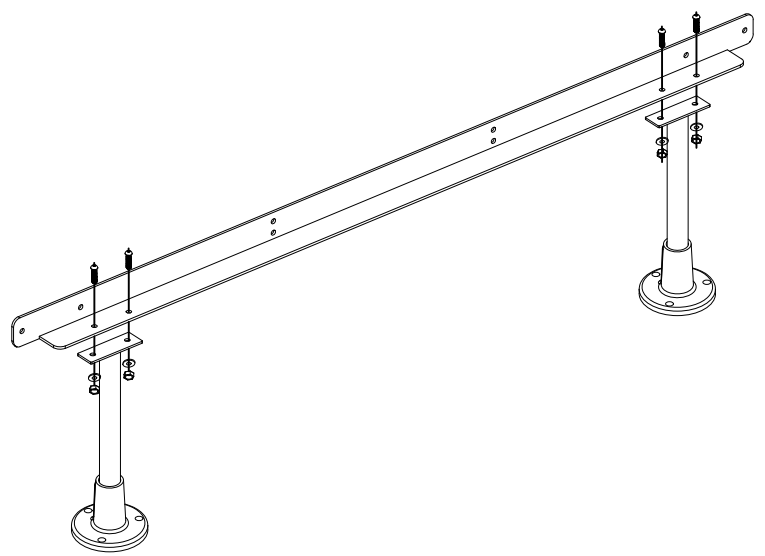

3

(Ø8*45)
X8

(M8)
X12

(M8)
X4

(Ø34)
X4

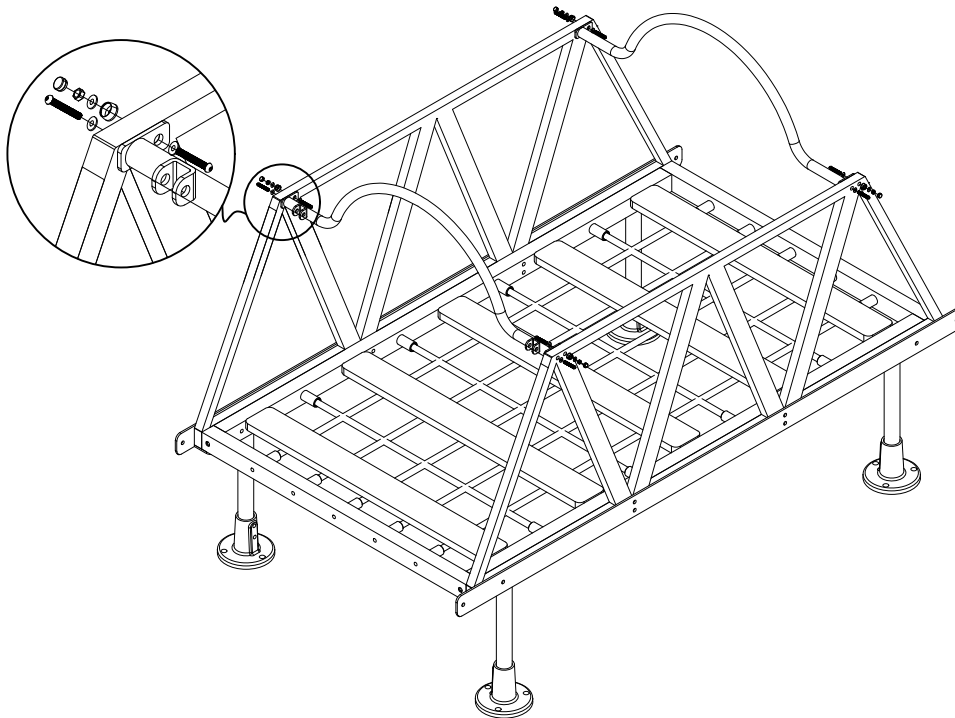

CAUTION:

- Do not allow children to climb on shelves.
- Do not use as a ladder or cart.
- Kinder dürfen nicht auf den Artikel klettern.
- Nutzen Sie den Artikel nicht als Leiter.

CARE AND CLEANING

- Clean wood with a damp cloth or sponge using warm water and mild soap. Wipe dry.
- Check for loose or worn parts periodically and tighten or replace as necessary
- Do not place unit near high heat.

-Das Holz kann mit einem nebelfeuchtem Lappen oder Schwamm und warmen Seifenwasser gereinigt werden. Wischen Sie danach trocken.

-Überprüfen Sie den Artikel regelmäßig auf lockere oder abgenutzte Teile, ziehen Sie Schrauben wieder fest oder ersetzen Sie wenn nötig Teile.

-Positionieren Sie den Artikel nicht in unmittelbarer Nähe von offenem Feuer.

Record the Batch-Number here. Information is located on the shipping carton and / or the product itself. Keep this sheet in an accessible place.

Notieren Sie die Batch-Nummer hier. Diese finden Sie entweder auf dem Verpackungskarton und / oder am Produkt selbst. Bitte heben Sie die Batch-Nummer für Rückfragen auf.

Model Number: **HW1-S358-A**

Batch-Number: _____

Distribution:
Wisdom Education Europe
Zum Poppschen Gut 3
09526 Olbernhau
GERMANY

www.wisdomeurope.com