

Assembly Instructions

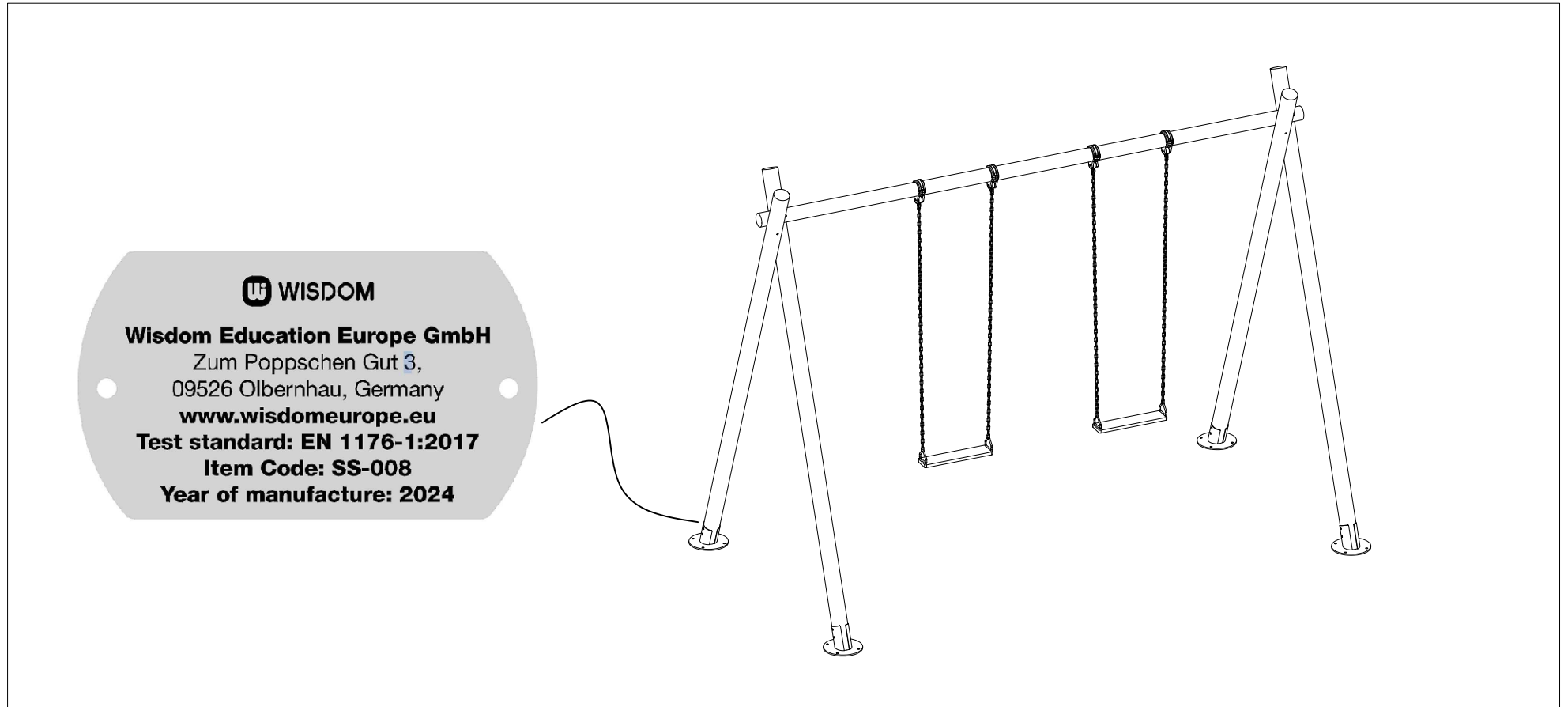

Item name: SS-008

Item code: Double Seat Swing

Assembly Instructions

1. Before installation, ensure that the site meets the below installation requirements.

- 1) Confirm whether the site has obvious slope affecting the installation. (The height difference of the concrete floor should not be more than 5cm, and the grass should be leveled when installing the equipment.)
- 2) Confirm whether there are immovable obstacles in the site and whether the site size conforms to the installation of this product (use zone shall be retained).
- 3) For the concrete floor, the post needs to be fixed to the ground with expansion screws. Ensure that the thickness of the concrete is more than 12cm (Concrete Strength \geq C30).
- 4) For the grass ground, it will need to dig a hole with at least 60CM deep for the post installation. Please check whether there are water, electricity, gas pipe and other factors under the site that may affect digging.
- 5) A minimum of five adults are required for assembly.

Only after the above conditions are met can the installation be performed. If necessary, please contact our company for technical support.

2. Product unpacking confirmation

When unpacking the product, please handle it with care. Protective flooring such as soft pads and cardboard should be laid at temporary storage site to prevent potential damage. If any components are damaged due to logistics, please contact the company to replace it in time, so as not to affect the installation.

3. Confirm the installation position of the product

Before installing the product, confirm the installation position with the customer. It is suggested to place the wall panels, fences and posts horizontally on the ground according to the design drawing to simulate the installation position, and confirm the use zone between the product and the surrounding area (no less than 183CM). After the customer's confirmation, install the products in the established position.

4. Notes

- 1) Children should be kept away from the product during incomplete installation, disassembly or maintenance to ensure safety. All screws should be tightened after assembly.
- 2) The expansion screws fixed to the ground need to be processed as the last step, and the product needs to be adjusted properly before fixing the expansion screws.
 - (1) Ensure that the post is vertical and does not tilt.
 - (2) Stand in the distance to see the posts in the same direction in a straight line (see from different directions), to ensure the product in good looking.

5. Installation tools

- 1) Impact drill, M12 impact drill bit, length not less than 12CM.
- 2) Suggest to equip with cordless screwdriver to speed up the construction schedule.
- 3) Scaffolding is recommended to facilitate the installation of square roof and hex roof.

If the site is the grass ground, the following tools should be equipped.

- 1) Laser level (when digging and pouring concrete to ensure that the posts are at the same level.)
- 2) Digging tools, such as spade, hammer, etc. (Small excavator is recommended.)
- 3) String (It is used to help locate the position.)

Overall Product Drawing

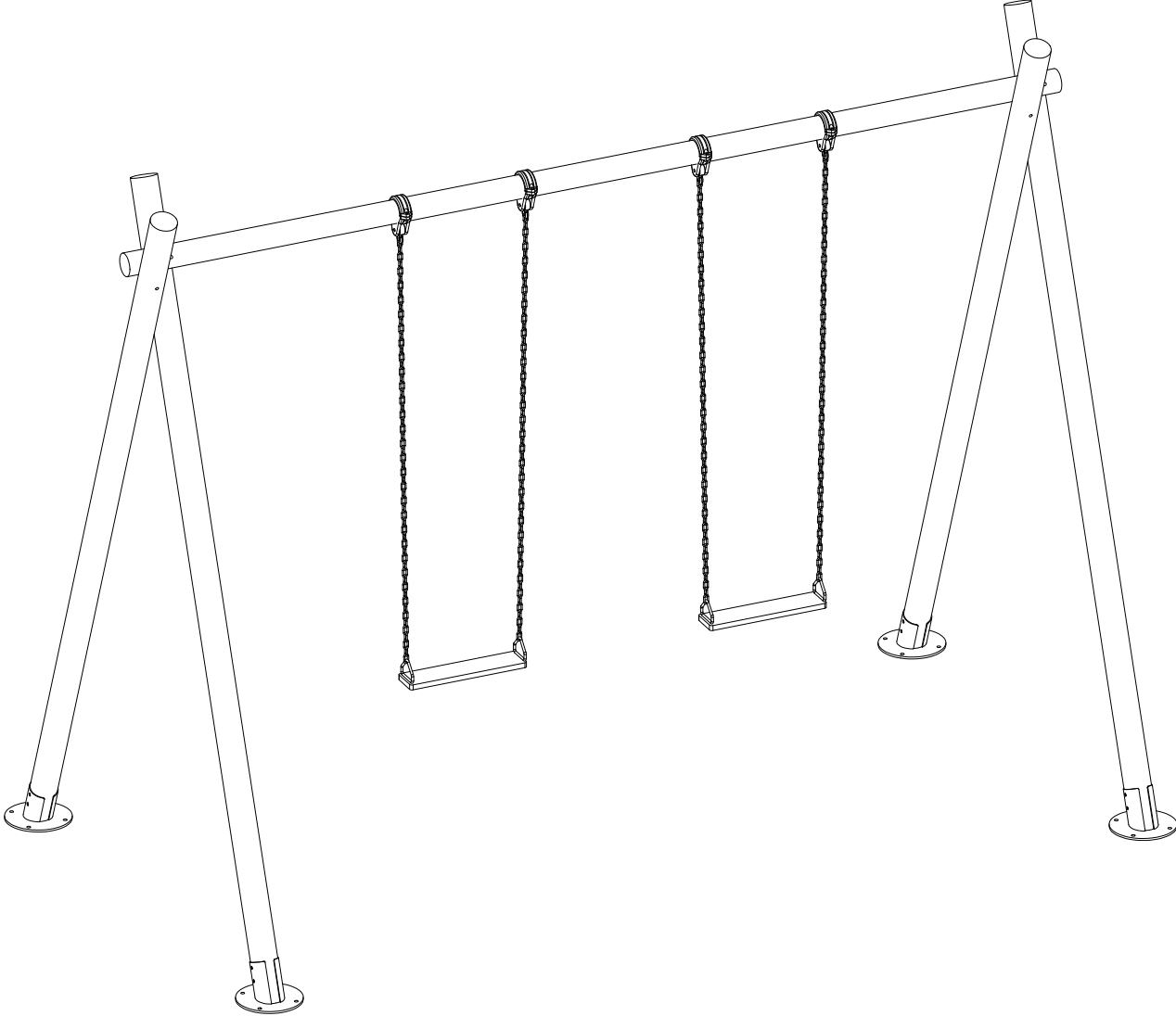

Use Zone

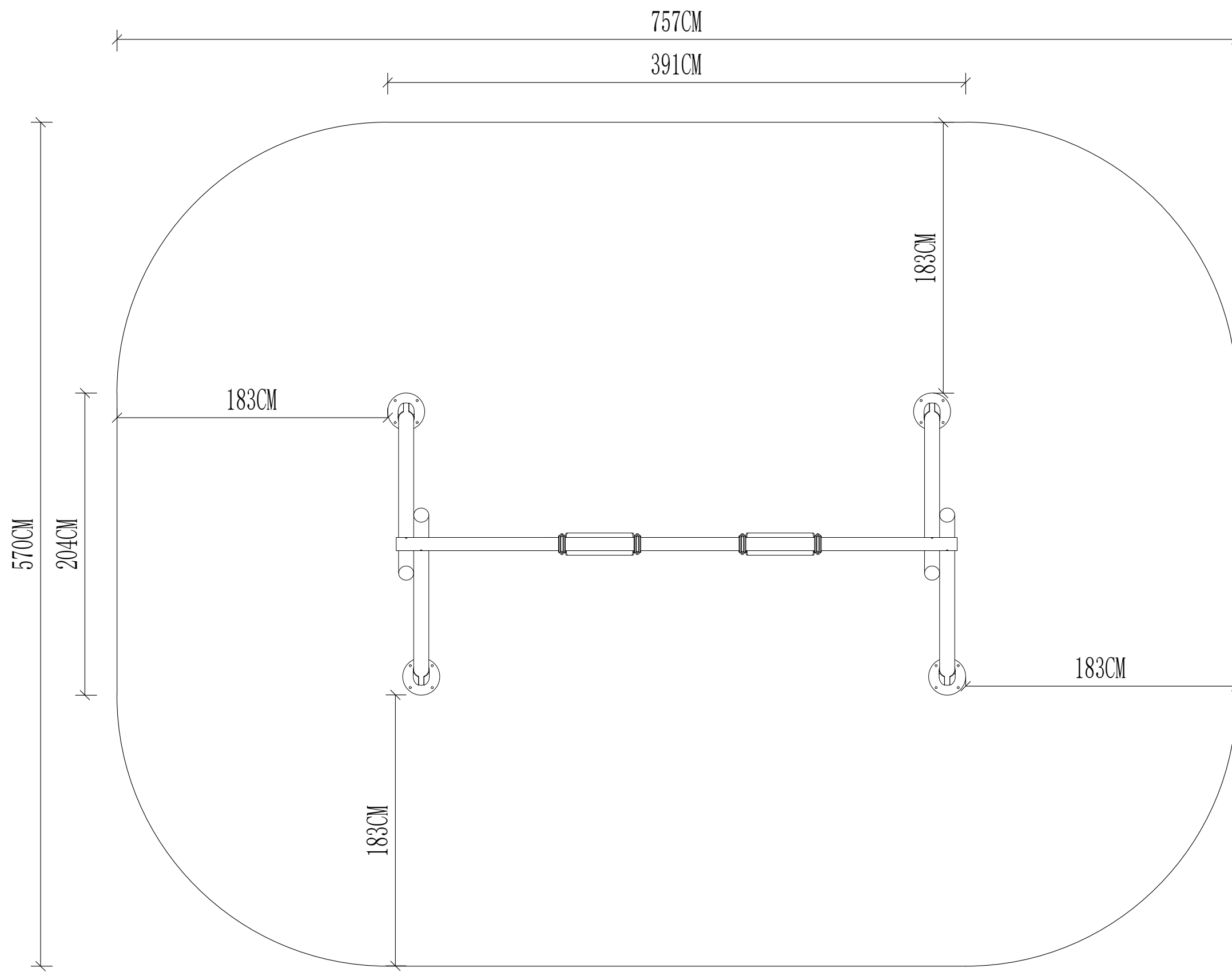

Use Zone

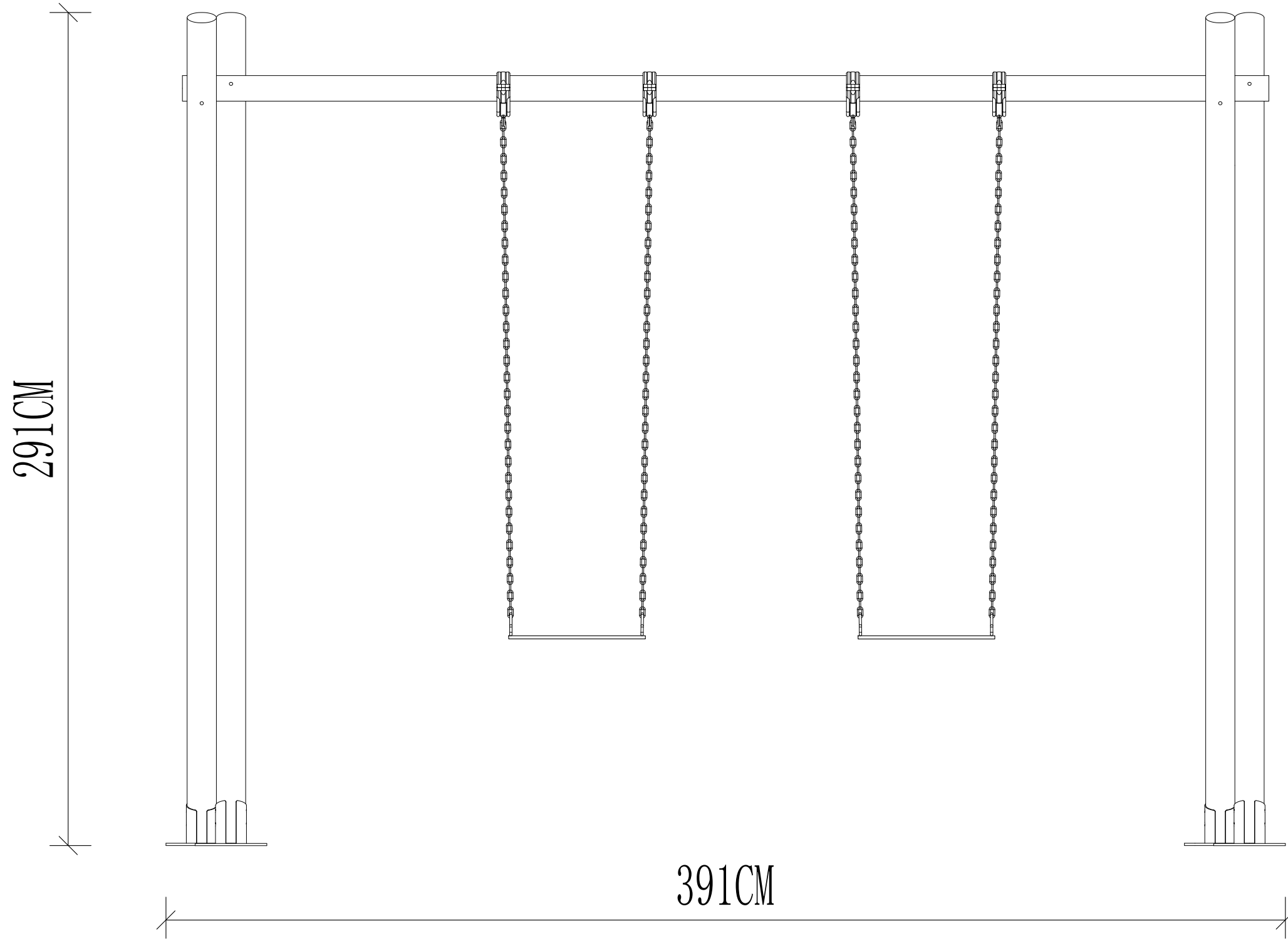

Post Footing Diagram

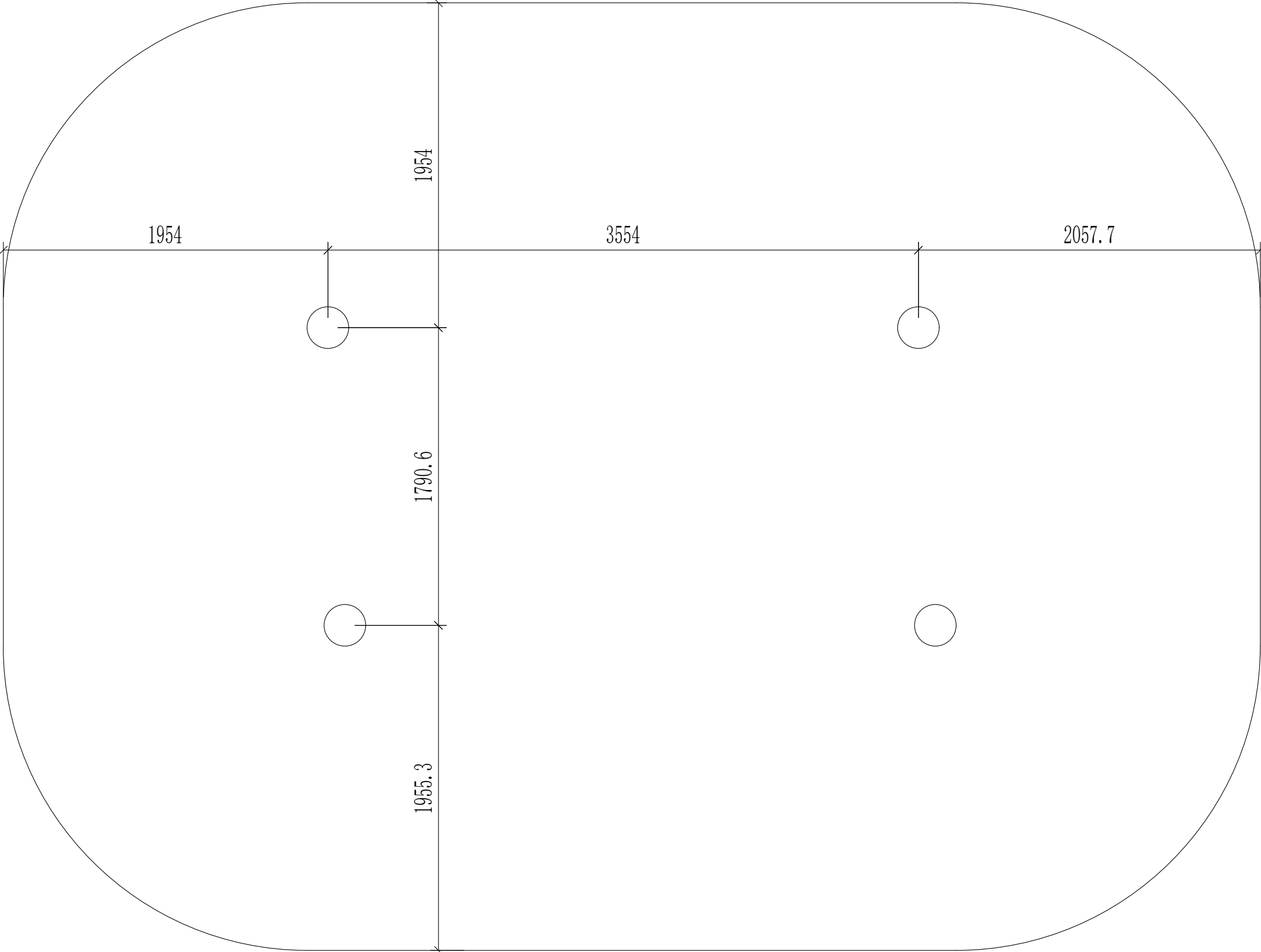



CAUTION:

- Do not allow children to climb on shelves.
- Do not use as a ladder or cart.

CARE AND CLEANING

- Clean wood with a damp cloth or sponge using warm water and mild soap. Wipe dry.
- Check for loose or worn parts periodically and tighten or replace as necessary
- Do not place unit near high heat.

Record the Batch-Number here. Information is located on the shipping carton and / or the product itself. Keep this sheet in an accessible place.

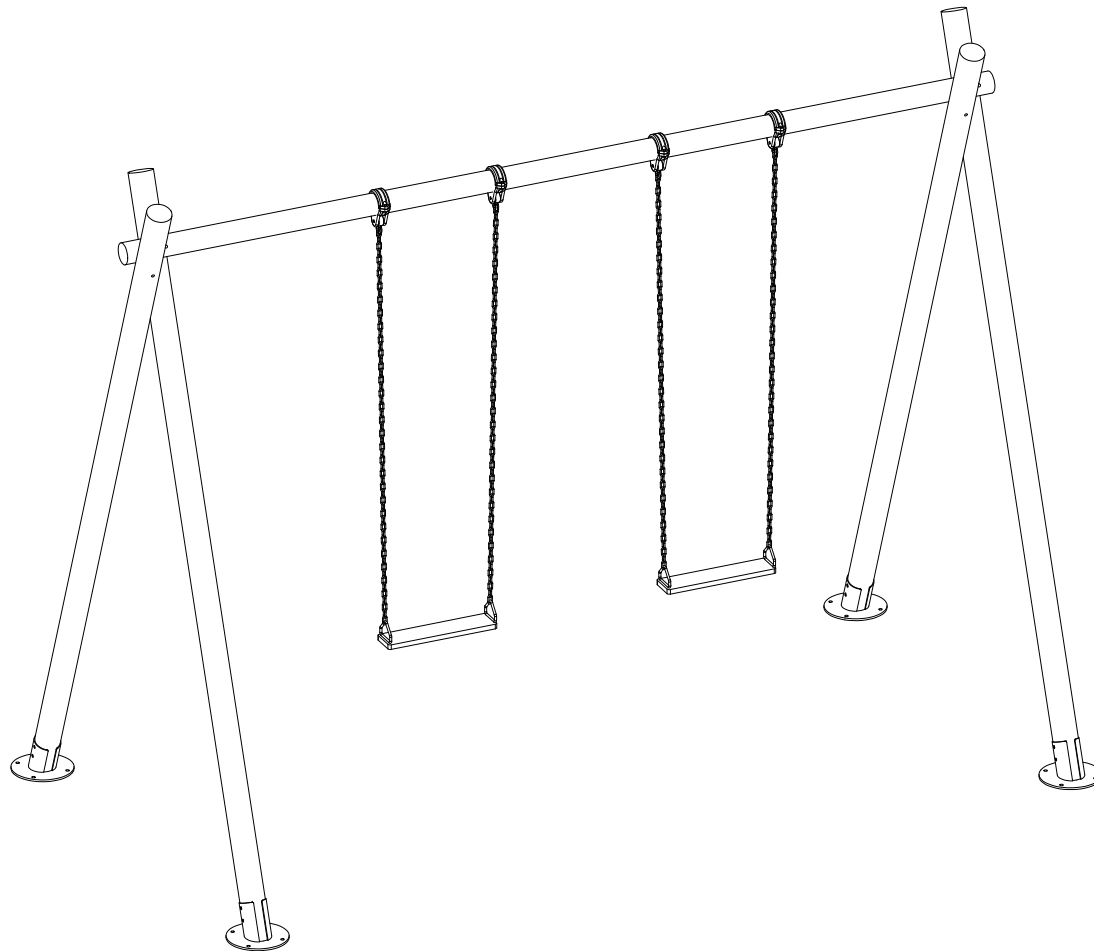

Model Number: **SS-008**

Batch-Number: _____

Distribution:
Wisdom Education Europe
Zum Poppchen Gut 3
09526 Olbernhau
GERMANY

www.wisdomeurope.com

INSTRUCTION MANUAL

Description:Berlin Toddler-Physical Activity Set

Item Code: **SS-008**

Imported into EU by: Wisdom Education Europe GmbH, Zum Poppaschen Gut 3, 09526 Olbernhau,Germany

Manufacturer: Wisdom Educational Product Co.,Ltd

Manufacturer Address: Building 4, Lane 2777, Baoan Road, Malu Town, Jiading District, Shanghai, China

Test standard: **DIN EN 1176-1: 2017, DIN EN 1176-3: 2017**
NEN EN 1176-1: 2017, NEN EN 1176-3: 2017

Overall Dimension: **391*204*291CM**

Weight: **NW:220KG,GW : 240KG**

INSTALLATION INSTRUCTIONS

- 1.Ensure the area is safe and devoid of any hazards prior to assembly,The minimum space will be:**757*570CM**.
- 2.A minimum of two adults are required for assembly.
- 3.The product and materials are intended for indoor or outdoor use under supervised conditions.
- 4.Check the quantity of spare part based on spare part list before assembly.
- 5.When installing,ensure ground is either a soft fall surface,or protected by a soft material such as cardboard or a blanket when assembling to avoid frame scratching.
- 6.Tighten all bolts after assembly.
- 7.Removal all assembly materials and tools from the play area before the equipment is used.
- 8.During the process of incomplete installation, disassembly, or maintenance, the children should stay away from the product to ensure safe.
- 9.The product can be fixed to the ground, and the below is the assembling intruction.

INSTRUCTIONS

1. Please read the instructions and warning labels carefully before use.
2. Inspect items and play area for any potential hazards prior to use.
3. Maximum number of people using the equipment at the same time is 2 .
4. User age group: 6-23 Months.
5. Never leave children unattended. Ensure constant adult supervision.
6. Please pay attention to the safety of the surrounding environment before use and avoid use under bad weather conditions.
7. The critical falling height is 0.6m (this is the maximum platform height), and the ground should be covered by protective surfacing materials. The materials should meet the corresponding safety standard EN1177, and the size should not be smaller than the use zone of the product.
Method 1: Sand layer, required size in 0.25-2mm, overall depth is not less than 22CM, monthly check to prevent the loss and potential risk.
Method 2: Wood mulch layer, required size in 20-80mm, overall depth is not less than 22CM, monthly check to prevent the loss and potential risk.
Method 3: Wood chip layer, required size in 5-30mm, overall depth is not less than 22CM, monthly check to prevent the loss and potential risk.
Method 4: Pea Gravel layer, required size in 2-8mm, overall depth is not less than 22CM, monthly check to prevent the loss and potential risk.
Method 5: Falling Mat, meet the corresponding safety requirements of EN1177.
8. If the material is damaged and needs to be repaired, please contact the manufacture to repair or replace.
9. Please ensure that the installation ground is horizontal during installation and keep it horizontal during use.
10. Max component is Stairs, dimension of max component is 98*56.8*84CM. dimension of max weight is 41.58KG

MAINTENANCE

1. Clean with a moist cloth.
2. Use neutral cleaners for cleaning.
3. Regularly inspect the product.
4. Follow the below inspection cycle to adequately inspect the product.
5. Fill in the inspection record after the inspection.
6. A further 2 layers of wood wax oil (also environmentally friendly) are also added for further protection.
For maximum product life we would advise to retreat with a further coat of wood wax oil each year.

INSPECTION INFORMATION

Inspection cycle	Inspection Project	YES/NO	Solution	Signature
Daily Inspection on Items	Check screws, bolts and fasteners are tightened.			
	Installed on a flat surfact and no hazards are present.			
	Equipment is free of dirt and moisture.			
	Hook and loop attachments are securely fastened.			
	Check for a signs of damage and wear.			
Monthly Inspection on Items(Except for Daily Inspection on Items)	Check screws are free of rust and damage.			
	Check parts are securely connected.			
	Check compliance labels are intact.			
Annual Inspection on Items(Except for Daily and Monthly Inspection on Items)	Check there is no extensive corrosion and replace if required.			
	Check for cracking or connecting part deterioration. Replace if required.			
	Check there is no excessive discolouration of components.			
	Check screws and connectors are in working order and not damaged or deteriorated.			
	Check compliance labels are legible.			
	Check the play area under the equipment is safe and level.			
	Check if the protective surfacing meet safety standards			

1

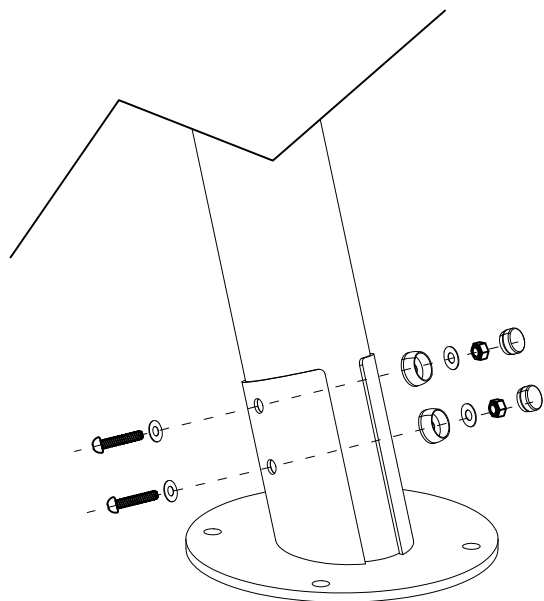

2

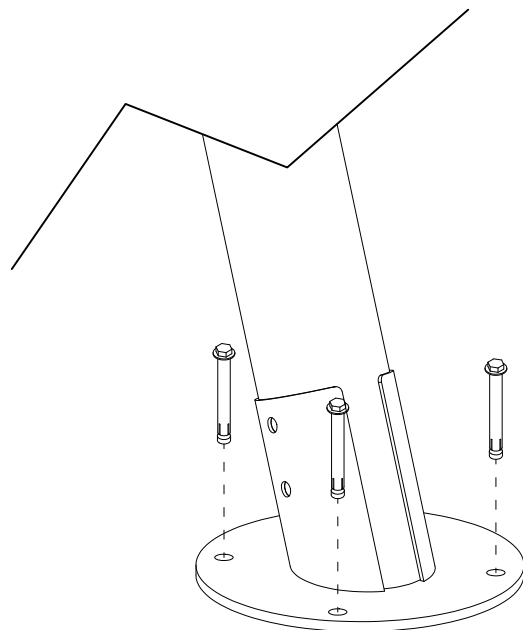
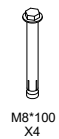

DGZHP048

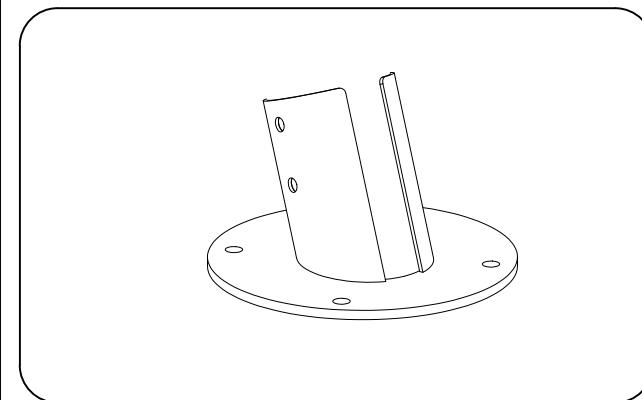

DGZHP048WJB

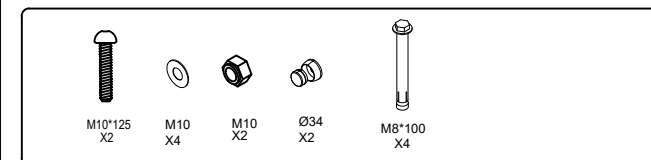

1



M10*220
X4



M10*230
X2



M10
X12



M10
X6

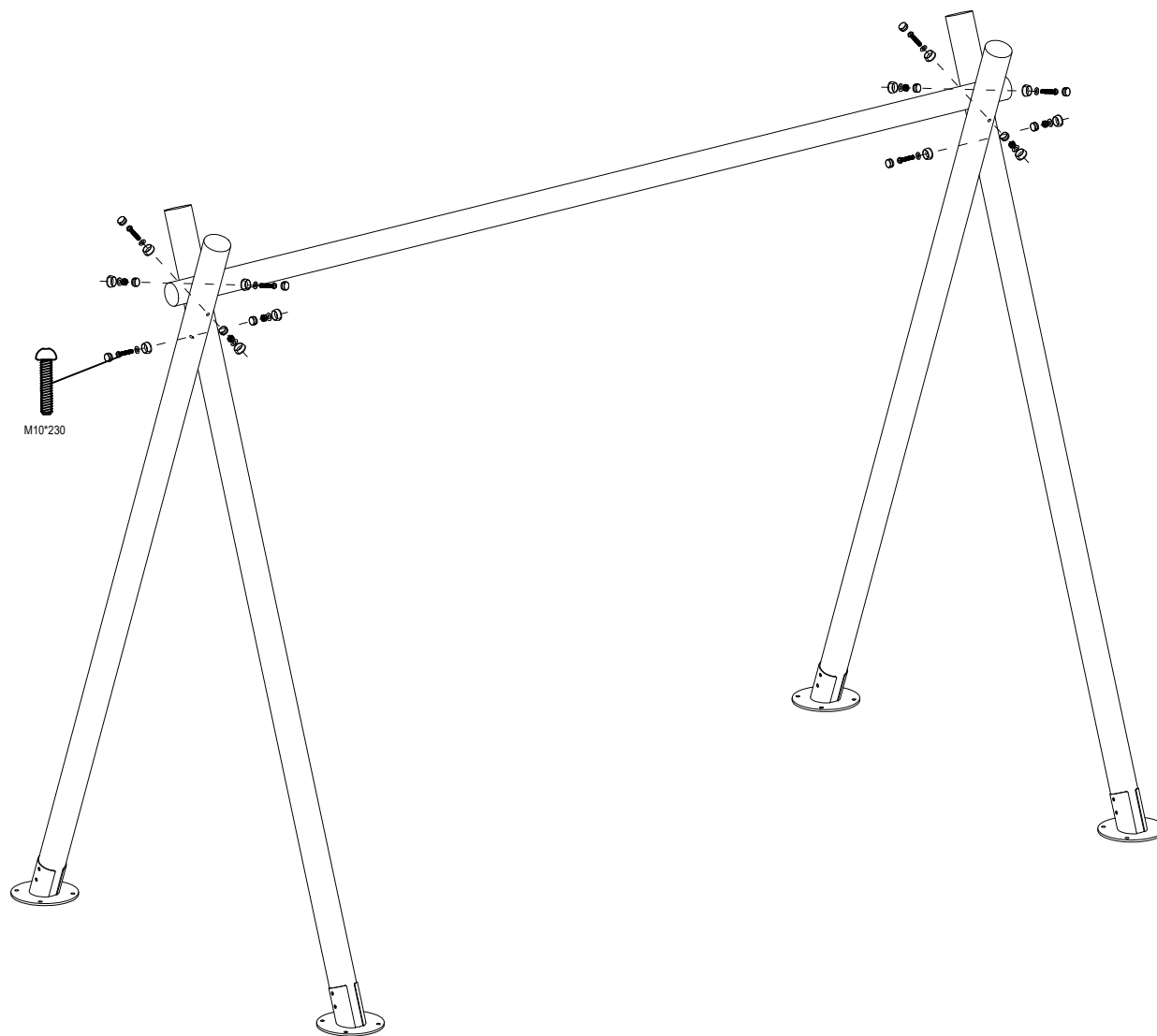

SS-008 Double Seat Swing

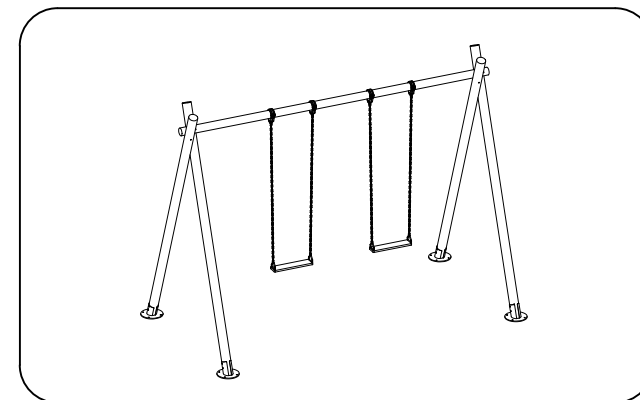

SS-008WJB Double Seat Swing- Hardware Package



M10*220
X4



M10*230
X2



M10
X12



M10
X6

2

